

»»» bstAIR

bstAIR 15-20



bstAIR



User benefits

The bstAIR 15-20 single stage boosters are designed with the highest requirements for reliability and low cost of maintenance. Air and nitrogen boosters are widely used in different industrial applications with outlet pressures of up to 40 bar.

Ultimate reliability and performance

- High-quality component materials
- Low oil carryover with use of special oil retention system

Energy efficiency

- Direct drive transmission
- A highly efficient IE3 IP55 motor

Quiet and safe operation

- Strong anti-vibration dampers
- Well balanced, V-type, single-stage pump

»»» Air and nitrogen boosters

There are many industries and processes where compressed air and nitrogen are used at higher pressures of up to 40 bar. PET blowing, laser cutting, pressure tests and abrasive cutting are among some of the widespread processes in which air or nitrogen boosters can be an integral part of the installation. The bstAIR booster can be connected to the plant's low-pressure network. The standard booster range has a discharge pressure of up to 40 bar, with a flow range of 0.4 m³/min to 3.6 m³/min.

Low cost of maintenance, reliability, and a thoughtful approach to details make the booster an attractive piece of technology to integrate into the production process.



»»» Booster technology: how does it work?

Air or nitrogen is compressed in a single-stage pump using the standard operating cycle of a piston compressor. Compression starts at a low pressure moving through the joint work of the inlet and outlet solenoid valves. The compressed air or nitrogen then enters the booster where it is further compressed up to 40 bar, in a single stage. The inlet pressure switch stops the booster when the inlet pressure exceeds the maximum allowed value or drops below the minimum allowed value. Cooling is provided by the axial fan installed on the shaft of the booster.

The booster is lubricated by the oil in the crankcase. The crankcase is vented via the oil separator and the oil breather, which allows operation with minimum oil carryover.

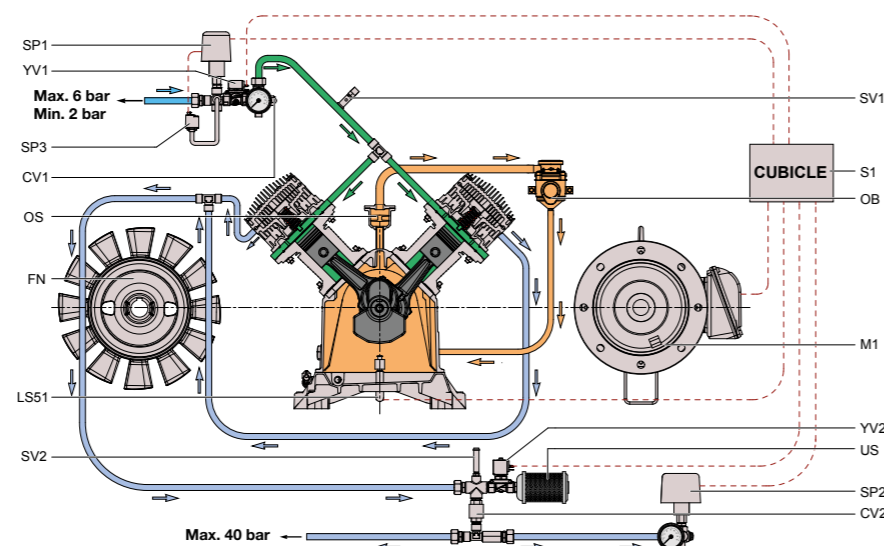

»»» Smart technical advantages



Highly reliable single-stage pump

- Advanced materials and treatment of main components
- Robust, reliable design and easy access for service
- Low vibration level

Direct-driven set

- Highly efficient IE3 motor as standard
- Fully enclosed air-cooled, IP55, F-class motor for heavy-duty operation

Electrical cubicle with soft starter

- Low electrical peaks
- Gradual stop of the motor
- 24V transformer is installed inside the cubicle

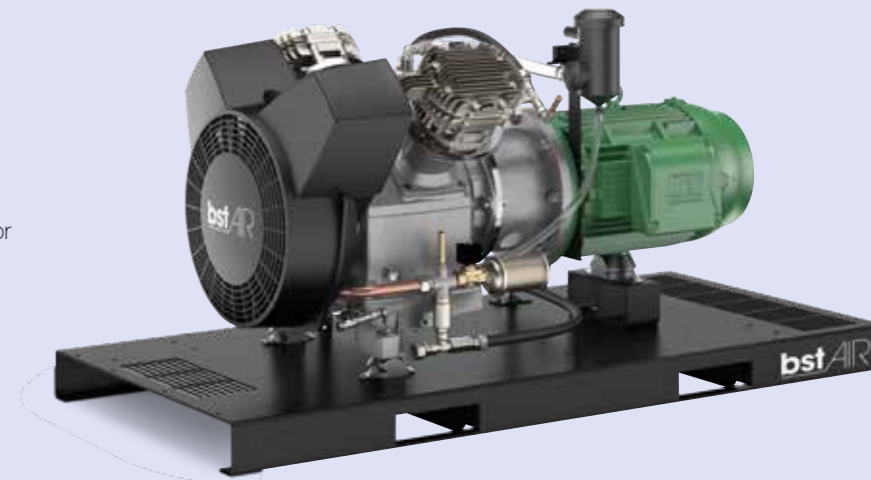

bstAIR 15

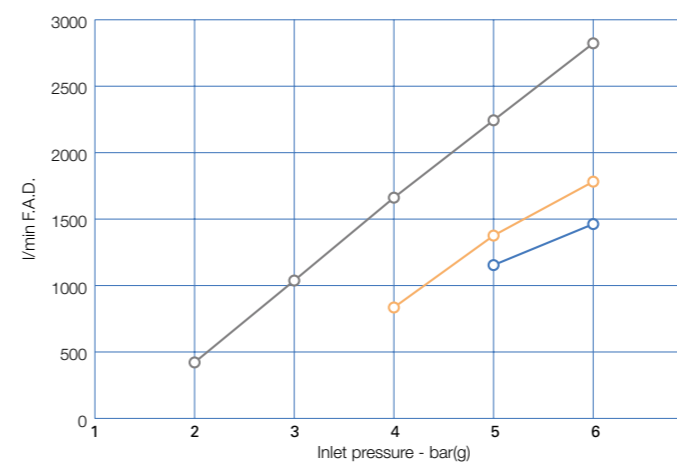

bstAIR 20

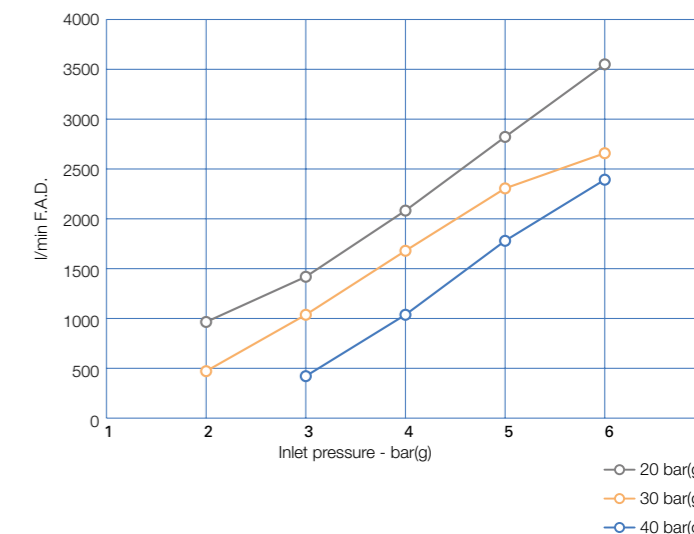

»»» Technical specifications

Model	Max. inlet pressure		Max. outlet pressure		Free Air Delivery		Recommended inlet flow		Motor Power		Noise level
	bar	bar	bar	bar	m ³ /h	l/s	m ³ /h	l/s	kW	hp	dB(A)
bstAIR 15	6	40	87.2	24.2	104.4	29.0	11	15	83		
bstAIR 20	6	40	144.0	40.0	172.8	48.0	15	20	83		

Unit performance measured according to ISO 1217, Ed. 4, Annex C-2009.
Mean noise level measured according to ISO 2151, Ed. 2004; tolerance 3 dB(A).

Model	Length (mm)	Width (mm)	Height (mm)	Weight (kg)
bstAIR 15	1600	700	780	205
bstAIR 20	1600	700	780	210

bstAIR 15-20 Air and Nitrogen Boosters

bstAIR



- A high-quality product and [technology you can trust](#)
- Choosing our high-performance compressor ensures the [availability](#) of compressed air
- Our products are [simple, easy to use](#), and highly [reliable](#)
- [Serviceability](#) and aftermarket are guaranteed
- Original parts and services
- Dealers are always nearby and complete the strong [partnership](#) you can expect



Increase your profits and improve your company's image



Contact your local sales representative now!

6999100480

