



Description	Model	Vessel ltr	Pressure		Air Displacement		Engine			Sound Power LwA dB(A)	Sound pressure 4 mt. dB(A)	Weight kg	Dimensions
			bar	psi	l/min	cfm	hp	kW	Type				
engineAIR 4/100 Petrol	Mobile	100	10	145	281	10	3,5	2,6	GX120 QX9	96	72	71	1090 x 420 x 1030
engineAIR 5/50 Petrol	Mobile	50	10	145	348	12	4,8	3,6	GX160 QX9	96	72	73	1000 x 410 x 870
engineAIR 5/100 Petrol	Mobile	100	10	145	348	12	4,8	3,6	GX160 QX9	96	72	94	1090 x 420 x 1030
engineAIR 5/200 Petrol	Mobile	200	10	145	348	12	4,8	3,6	GX160 QX9	96	72	120	1500 x 450 x 1100
engineAIR 5/11+11 Petrol	Mobile	11+11	10	145	348	12	4,8	3,6	GX160 QX9	96	72	70	1070 x 770 x 1040
engineAIR 5/11+11R Petrol	Rollbar	11+11	10	145	348	12	4,8	3,6	GX160 QX9	96	72	70	1070 x 770 x 1040
engineAIR 7/25+25R Petrol	Rollbar	25+25	10	145	570	20	7,1	5,3	GX240 QX B7	96	72	143	1235 x 835 x 1100
engineAIR 7/270 Petrol	Stationary	270	14	203	476	17	7,1	5,3	GX240 QX E4	104	80	223	1395 x 745 x 1500
engineAIR 11/270 Petrol	Stationary	270	14	203	741	26	10,7	8,2	GX340 QX E4	104	80	235	1395 x 745 x 1500
engineAIR 8/270 Diesel	Stationary	270	14	203	630	22	7,5	5,5	15LD 350	110	86	239	1395 x 745 x 1500
engineAIR 11/270 Diesel	Stationary	270	14	203	990	35	10,9	8,2	15LD 440	110	86	258	1395 x 745 x 1500
Bl engineAIR 8/270 Diesel 2,2KvA*	Stationary	270	14	203	408	14	7,5	5,5	15LD 350	110	86	265	1395 x 745 x 1500
Bl engineAIR 11/270 Diesel 2,2KvA*	Stationary	270	14	203	570	20	10,9	8,2	15LD 440	110	86	270	1395 x 745 x 1500
engineAIR 4 Petrol	BM	0	10	145	281	10	3,5	2,6	GX120 QX9	96	72	57	860 x 490 x 750
engineAIR 5 Petrol	BM	0	10	145	348	12	4,8	3,6	GX160 QX9	96	72	63	860 x 490 x 750
engineAIR 7 Petrol	BM	0	14	203	476	17	7,1	5,3	GX240 QX E4	104	80	117	1200 x 685 x 880
engineAIR 11 Petrol	BM	0	14	203	741	26	10,7	8,2	GX340 QX E4	104	80	128	1200 x 685 x 880
engineAIR 12 Petrol	BM	0	11	160	893	32	11,7	8,8	GX390	104	80	142	1200 x 685 x 880
engineAIR 8 Diesel	BM	0	14	203	630	22	7,5	5,5	15LD 350	110	86	142	1200 x 685 x 880
engineAIR 11 Diesel	BM	0	14	203	990	35	10,9	8,2	15 LD 440	110	86	151	1200 x 685 x 880
engineAIR 12 Diesel	BM	0	11	160	1050	37	12	8,8	15 LD 500	110	86	154	1200 x 685 x 880
Bl engineAIR 8 Diesel 2,2KvA*	BM	0	14	203	408	14	7,5	5,5	15LD 350	110	86	157	1200 x 685 x 880
Bl engineAIR 11 Diesel 2,2KvA*	BM	0	14	203	570	20	10,9	8,2	15LD 440	110	86	184	1200 x 685 x 880
Bl engineAIR 12 Diesel 3KvA*	BM	0	11	160	1000	35	12	8,8	15 LD 500	110	86	201	1200 x 685 x 880

* Air delivery will reduce when generator is used at high capacity



Your Authorized Distributor

1530016666

Pictures used in this leaflet are indicative and not contractually binding.

© 2012, EngineAir. All rights reserved. All mentioned brands, product names, company names, trademarks and service marks are the properties of their respective owners. Our products are constantly being developed and improved. We thus reserve the right to modify product specifications without prior notice.

engineAIR

The unplugged generation

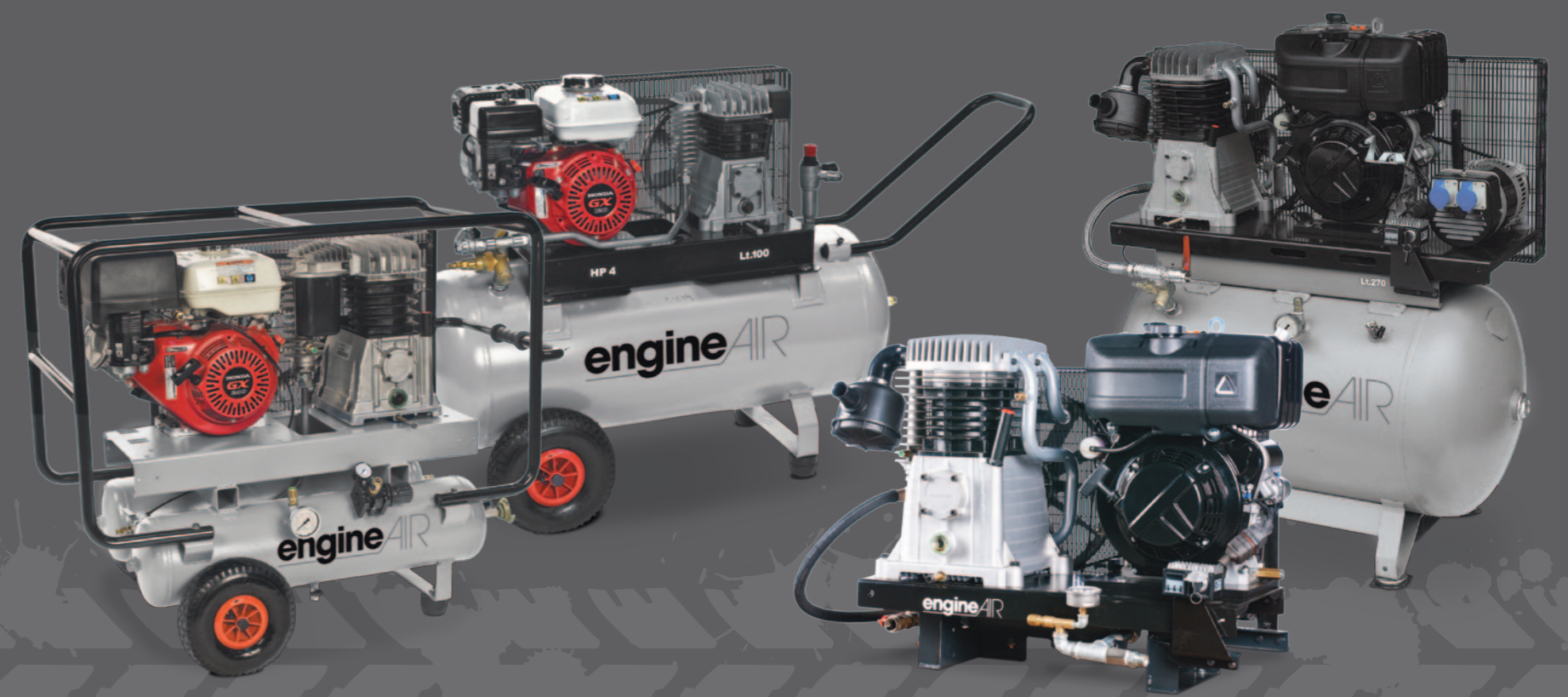

Petrol and diesel engine driven piston compressors
for your remote applications



Versatile engine compressors for remote applications

The freedom to do what you want, when you want, wherever you want. To be independent under all circumstances. Who wouldn't like that? As a small building contractor or a larger construction company, if you are in harvesting business or a farmer; this is your tool.

You'll be excited about this: a range of unplugged diesel and petrol engine belt driven compressors that are easy to move, that can cope with different air demands, that can power multiple tools at the same time and simultaneously provide a steady air flow; the BlengineAIR range comprises a two-in-one solution that can provide you with both air and electricity in remote locations.

With these versatile engine compressors you are totally independent from energy sources, giving you total availability of compressed air in all circumstances. Giving you total freedom.



Petrol Engine

Supersilenced version
Worldwide service support

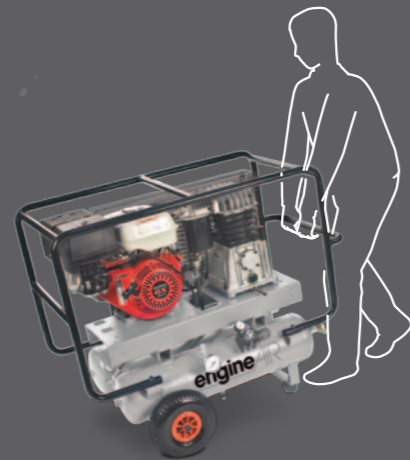

Metal Rollbar
Offers full protection.
Easy to carry, easy to move

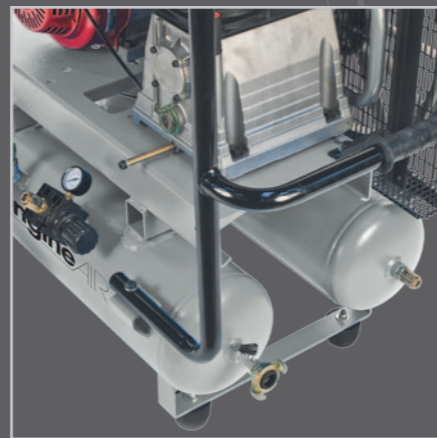

Twin tank version:
3 connections for 2 pressures and 1 big flow
Inbuilt connection flexibility for different demands



Ergonomic handle and large pneumatic tyres
For easy movement over difficult terrain

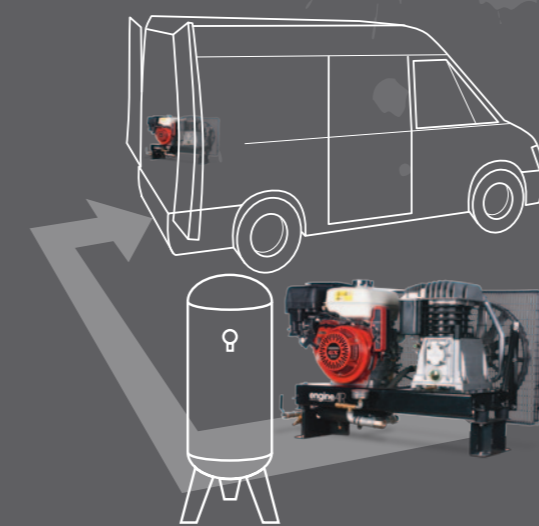

Easy to install for any kind of application
Pre-installed: just connect to a vessel and you are ready to go



Diesel Engine

Low fuel consumption

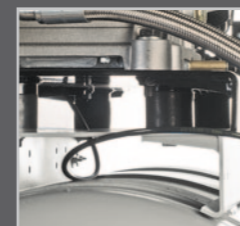

Anti-vibrating pads
Less vibrations, lower noise level and increased life time of your outside buddy



Easy maintenance
Led control panel, oil pressure and battery recharge indicator

Bi-Energy

The two-in-one solution with small footprint

One powerful motor, supplying both air and energy. Generator with electricity plug at 230 volt

2.2 kva (max)

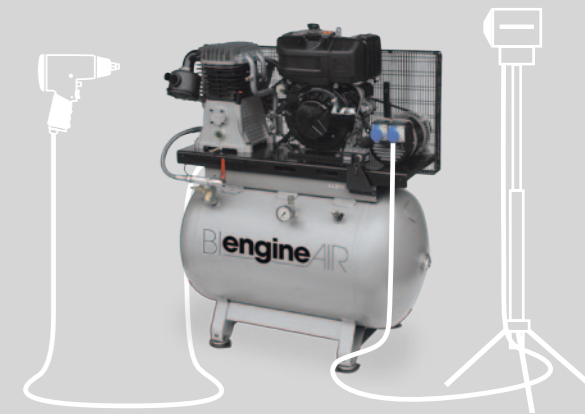

BlengineAIR

engineAIR